

**TAMLYN**<sup>®</sup>  
UNITED KINGDOM

**XtremePlank**<sup>™</sup>



## installation Guide (Horizontally fixed)



## General notes

The integrity and long-term performance of coated aluminium can be enhanced or diminished by the way it is handled and installed on site. Keep the product off the ground and dry until it is ready to be installed. The coating on this product has a guarantee of up to 30 years\*, and because it is aluminium, has a lifespan in excess of 100 years.

Good housekeeping and preparation during installation will ensure a beautiful finish for years to come.

\* Subject to project location and environmental conditions.

- **Tools;** a sheet nibbler jig saw or circular saw can be used to cut Aluminium panels. If using a jig or circular saw, use the appropriate blades and lower speeds to minimise frictional heating on the coating. The sheet nibbler has been especially developed for this purpose.

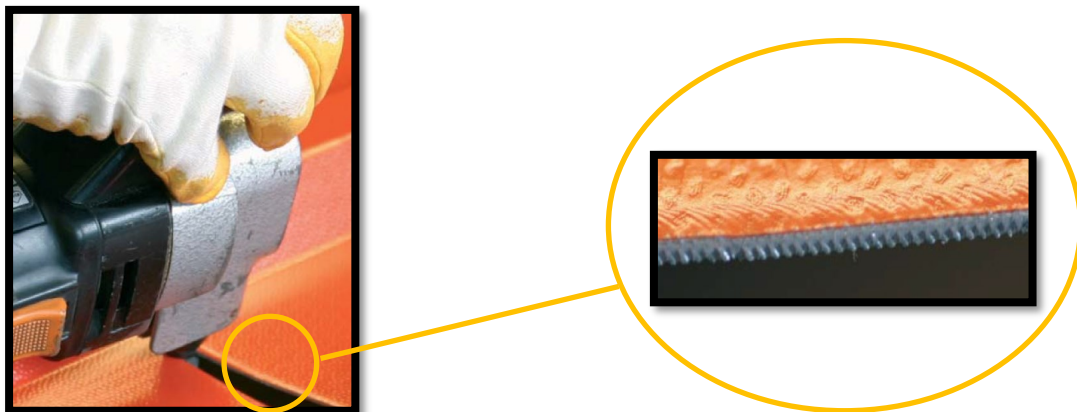

- DO NOT use a hack saw or abrasive disc as these can leave an uneven, poorly finished cut. These methods also cause frictional overheating and abrasion which can damage the coating.

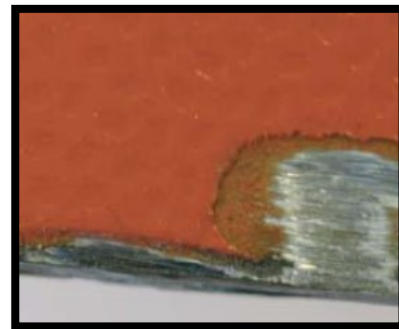

For further information and advice please contact Tamlyn UK on 07841 332923  
or email [sales@tamlyn.uk](mailto:sales@tamlyn.uk)

# XTREME PLANK ACCESSORIES

(All Xtreme trims are in 3metre standard lengths)

## Universal trim carrier

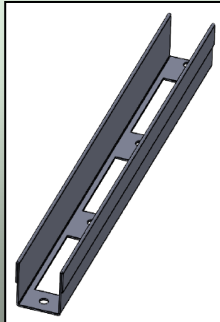
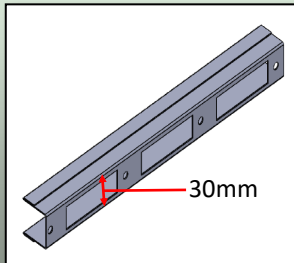

← Aluminium trim used as a carrier for all panel plank and soffit trims. (except panel corner trim).

External aluminium corner trim to cover two panel edges at the corner detail.

## External panel corner trim

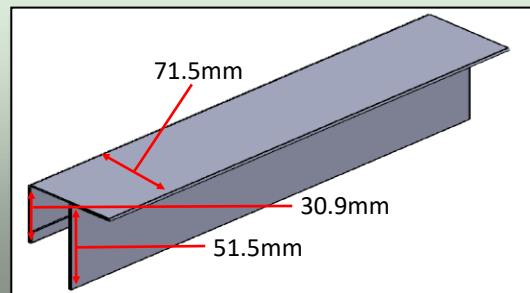

## 4 Position panel trim (single fin)

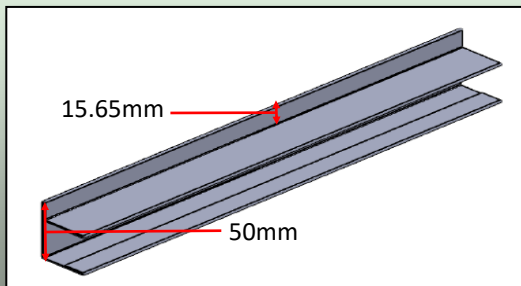

← Aluminium cover trim used vertically left or right, or as a header and base trim for cut or complete panels.

Aluminium cover trim used vertically between panels or as a base trim for cut or complete panels where a drip angle is required.

## 2 Position panel trim (double fin)

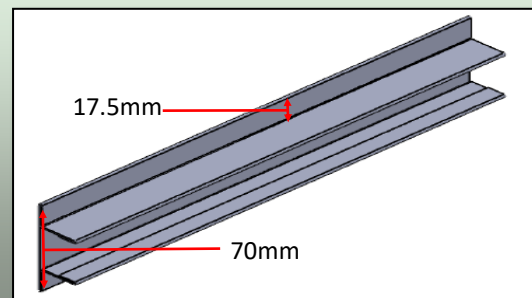

## Cut edge panel support profile

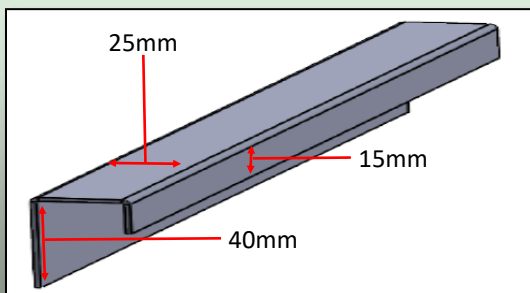

← Aluminium support trim used with a cut edge panel for edge support.

# XTREME PLANK ACCESSORIES

## Top hat

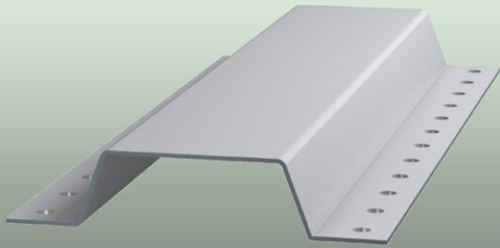

Galvanised steel / aluminium top hat profile. 0.7 / 0.9 / 1.2mm gauge (solid or vented)

25mm x 25mm x 60mm x 25mm x 25mm

← 3m lengths.

Self adhesive, black EPDM jointing tape used as an isolating membrane between the steel top hat and aluminium panel. Meeting the requirements of DIN 18516 part 1. 0.75mm x 70mm and 25m long

## Tamlyn Isolating tape

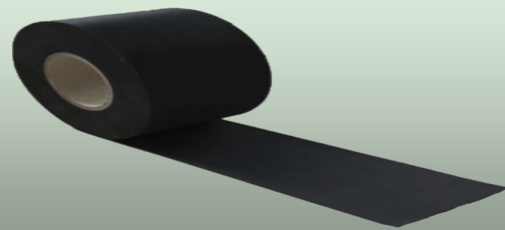

## Fixing for steel top hat

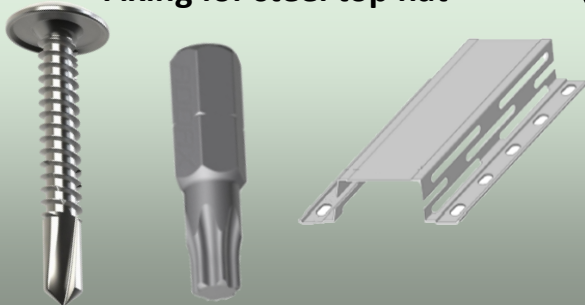

Bi metallic Torx™ head self drilling screw for securing panel to steel top hat. Coated carbon steel (with washer) or Austenitic stainless steel A2

← (304 grade 5.5 x 25mm.)

Bi metallic hex head screw for securing façade panel to timber purlins. Coated carbon steel (with washer) or austenitic stainless steel A2 (304grade) 6.3 x 25mm. →

## Fixing for timber batten

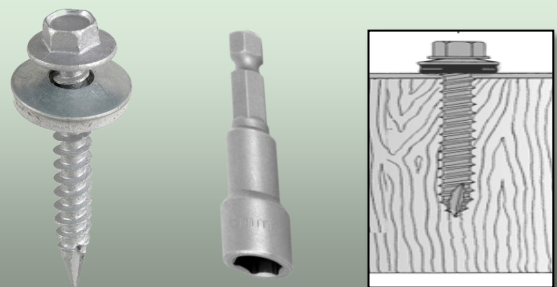

# Installation example

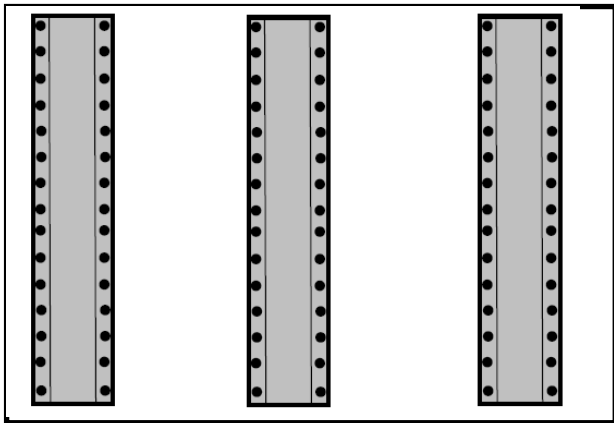

1

Fix top hat sections to the substrate using appropriate fixings and centres in line with the project requirements

2

Ensure the top hat is free from grease and dust and affix isolating tape to each top hat section. Press the tape firmly to the top hat so there are no air bubbles or unadhered areas.

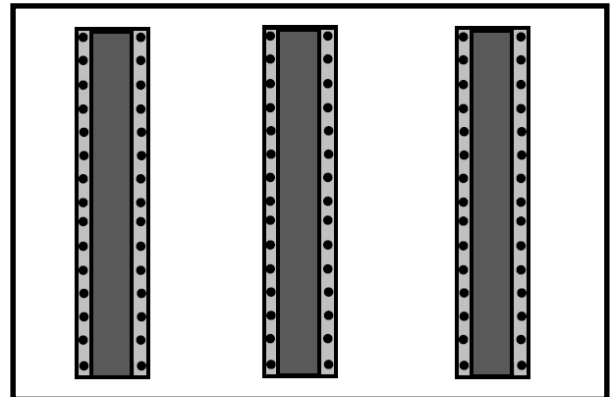

3

Line up the first panel in the desired position starting at the top of the elevation. Attach to the top hat using suitable fixings along the top and bottom edges

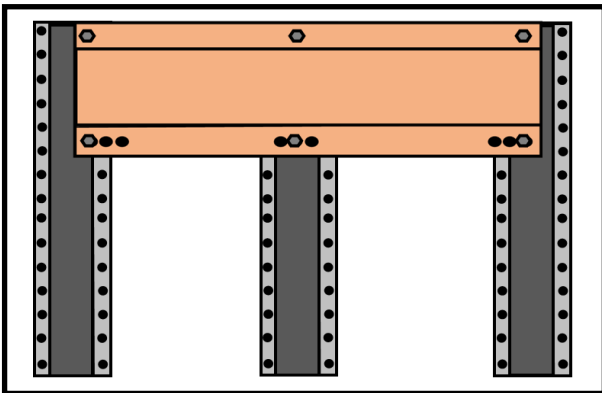

4

Align the second panel and slide into the female joint on the previously fixed panel. Gently tap into position using a rubber or soft headed mallet. Once you are happy with the level and that it has the correct joint gap fix into place at each top hat position.

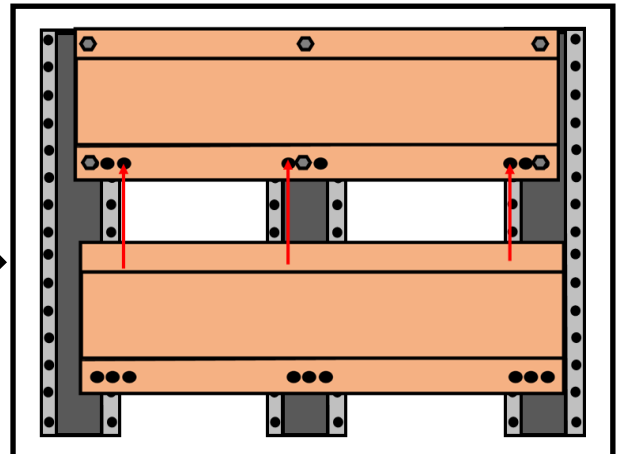

## Installation example

5

Repeat the process with the existing panels until you reach the desired base of the elevation. To finish off the top and bottom panels the 2 way or 4 way trim can be used depending on required aesthetic or if a drip angle is required.

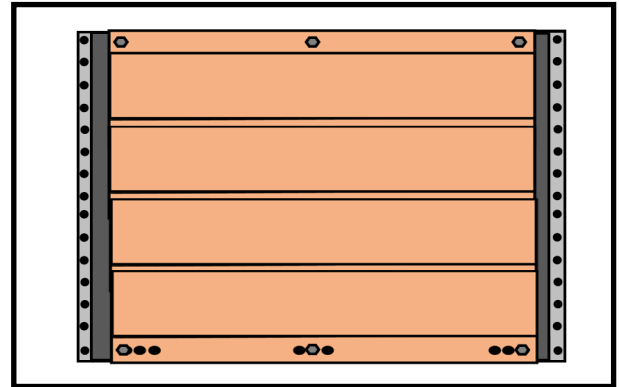

6

Place the universal carrier trim over the existing fixings and screw into the spaces in between the cut outs until you are sure of a positive fix.

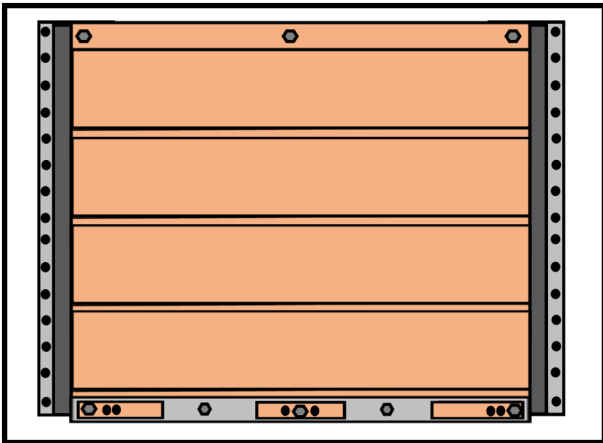

7

Line up the 2 or 4 way trim and gently snap into place over the universal carrier trim. Repeat the process everywhere you require a trim at the end of a vertical or horizontal run.

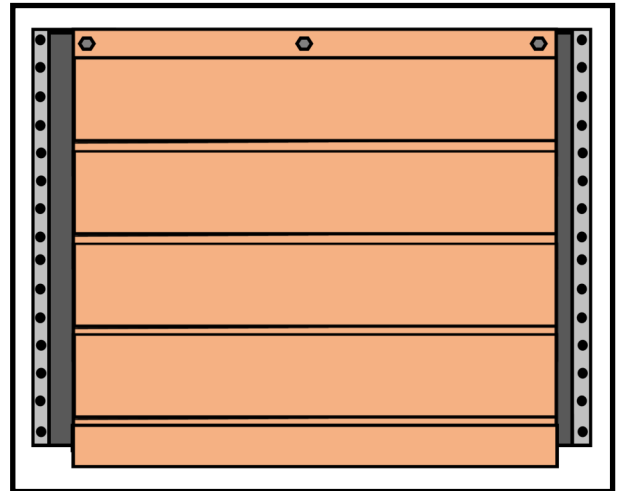

8

If you have to cut a panel along its length or width it is advised to install a cut edge panel support profile to support the cut end. This is installed before the last panel is fixed into place so that the fixings are hidden behind the panel.

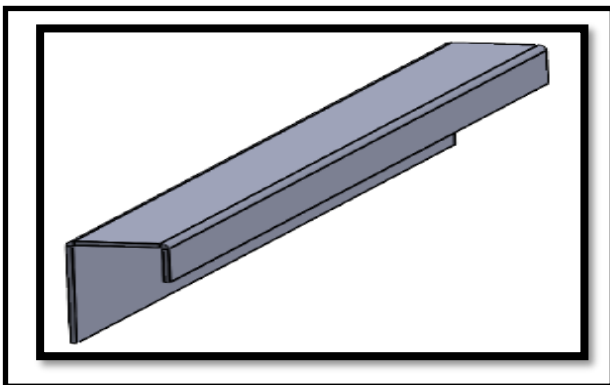

# TAMLYN<sup>®</sup>

UNITED KINGDOM

UK Sales office: 01386 570898  
sales@tamlyn.uk

[www.tamlynbuildingproducts.co.uk](http://www.tamlynbuildingproducts.co.uk)

